

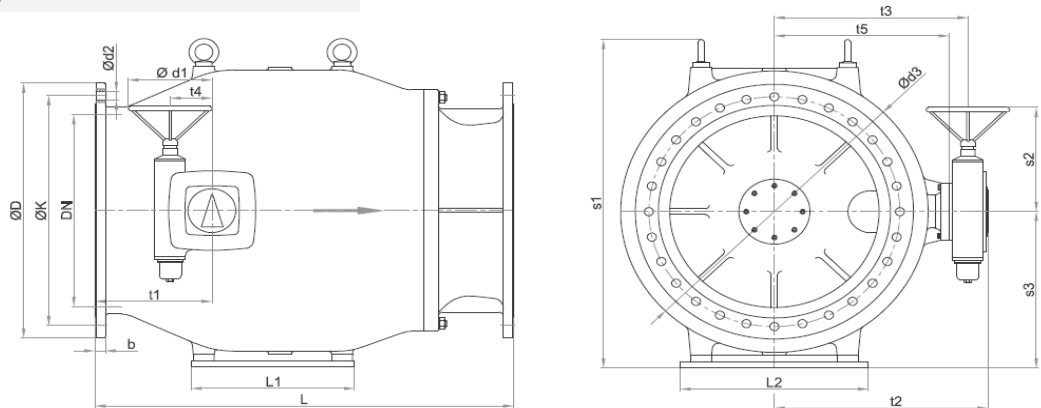

Valve Type	Needle valve	Hydrostatic Test	Acc. to DIN EN 12266-1/ API Std. 598/ ISO 5208 Body Test: @ 1.5*PN, Seat Test @ 1.1*PN
Valve Features	Soft Sealing (Resilient seated) Uni-Directional Sealing Tight Shut-Off Closure K and Kv Parameter Acc. to Mirab catalogue Linear Relationship between Flow rate and valve Opening percentage Different shape for Outlet Cylinder (Plain, Vaned, Perforated, Slotted) Renewable seat and guides	Coating System	Electrostatic Epoxy Powder, RAL 5005 Min DFT 250 micron (Food Grade)
Application	Pressure and Flow rate regulation	Actuator	Gearbox, Worm type Part-Turn, Open-Close Duty With Open-Close Indicator Material Ductile Iron, Epoxy Coated With Open/ Close End Stop Adjustable Swing Range 0-100% Opening Flange Acc. to EN ISO 5211 Closed Clockwise Rotation
Fluid	Raw water, Drinking water		
End Connection type	Flanged, RF		
Connection Standard	DIN EN 1092-2 (DIN 2501) PN10		
Valve Size Range	DN 200 ~ DN 1800 (NPS 8 ~ NPS 72)		
Body Rating	PN10		
Temperature Rating	Up to 70 °C		
Design Std.	Mirab Std.		
Face to Face Std.	Mirab Std.		
Body & Bonnet	Ductile Iron DIN EN 1563 GJS-400-15 (GGG40)		
Piston	Stainless Steel ASTM A351 CF8 (1.4308)		
Body seat	Seat Ring: Stainless Steel ASTM A351 CF8 (1.4301) Vaned Ring: Aluminum Bronze ASTM B148 C95200		
Piston Seat	EPDM Rubber		
Shaft	Stainless Steel ASTM A276 Type 420 (1.4021)		
Crank shaft	Stainless Steel ASTM A276 Type 304 (1.4301)		
Shaft Sealing	O-Ring (NBR)		



Dimension:



PN 10	DN	L	ØD	ØK	Ød2	n	b	Ød1	Ød3	t1	t2	t3	t4	t5	s1	s2	s3	L1	L2	Weight
	mm	mm	mm	mm	mm	mm	mm	mm	mm	mm	mm	mm	mm	mm	mm	mm	mm	mm	mm	kg
200	400	340	295	23	8	20	250	340	110	313	255	63	210	423	255	205	-	-	106	
250	500	395	350	23	12	22	250	376	150	333	275	63	230	483	255	235	-	-	150	
300	600	445	400	23	12	24,5	250	448	160	398	337	80	280	542	263	260	-	-	242	
350	700	505	460	23	16	24,5	250	522	200	472	405	100	330	622	303	300	-	-	397	
400	800	565	515	28	16	24,5	250	588	215	507	440	100	365	710	303	363	340	420	516	
450	900	615	565	28	20	25,5	250	640	248	527	460	100	385	751	303	365	340	500	661	
500	1000	670	620	28	20	26,5	400	732	280	582	515	100	440	863	393	442	400	530	932	
600	1200	780	725	31	20	30	400	876	318	645	575	125	500	1043	398	530	460	600	1473	
700	1400	895	840	31	24	32,5	400	1020	355	720	650	125	575	1212	398	610	540	800	2077	
800	1600	1015	950	34	24	35	400	1165	420	805	735	125	660	1370	398	690	590	900	2936	
900	1800	1115	1050	34	28	37,5	400	1360	485	899	825	160	750	1600	478	770	770	900	3845	
1000	2000	1230	1160	37	28	40	400	1470	560	984	958	160	835	1716	478	817	780	900	5582	
1200	2400	1455	1380	41	32	45	400	1810	660	1175	1080	200	990	2148	544	1040	1000	1400	9010	
1400	2800	1675	1590	44	36	46	400	2185	866	1444	1330	250	1200	2428	604	1180	1200	1500	14600	
1600	2800	1915	1820	50	40	49	400	2185	866	1444	1330	250	1200	2428	604	1180	1200	1500	14900	
1800	2900	2115	2020	50	44	52	500	2600	790	1805	1645	315	1500	3020	684	1480	1730	1580	20100	