



MIRAB INDUSTRIAL VALVES

No.: CAF-FO-50-1000-10

Automatic Control Valve Data Sheet

Rev.: 00 , Date: Jan 2023

Valve Type	Float Level Control Valve (Floater) On/ Off type	Hydrostatic Test	Acc. to DIN EN 12266-1/ API Std. 598/ ISO 5208 Body Test: @ 1.5*PN, Seat Test @ 1.1*PN Functional test
Valve Features	Sensitive and Accurate Level Control Straight Pattern Globe Body Soft Sealing (Resilient seated) Uni-Directional Sealing K and Kv Parameter & Recommended Inlet/ Outlet Pressure & Min, Normal and Max. Flow Rate Acc. to Mirab Catalogue. Full Port Body (Up to DN200) Reduced Port Body (DN250 to DN1000)	Coating System	Electrostatic Epoxy Powder, RAL 5005 Min DFT 250 micron (Food Grade)
Application	Valve fully Open when the fluid level reach to the preset low level and closes tight when the fluid level reach to the preset high level	Actuator	Pilot Operated (Fluid actuated) Accessories: Tubing and Stariner (Stainless Steel 304) 2 way Pilot and Float Ball Valves
Fluid	Raw water, Drinking water		
End Connection type	Flanged, RF		
Connection Standard	DIN EN 1092-2 (DIN 2501) PN10/PN16		
Valve Size Range	DN 50 ~ DN 1000 (NPS 2 ~ NPS 40)		
Body Rating	Up to 16 Bar		
Temperature Rating	Up to 70 °C		
Design Std.	Mirab Std.		
Face to Face Std.	DIN EN 558-1 Series 1 (DIN 3202-F1)		
Body & Bonnet	Ductile Iron DIN EN 1563 GJS-400-15 (GGG40)		
Disc	Ductile Iron DIN EN 1563 GJS-400-15 (GGG40)		
Body seat	Stainless Steel ASTM A351 CF8 (1.4308)		
Disc Seat	EPDM Rubber		
Axle	Stainless Steel ASTM A276 Type 304 (1.4301)		
Axle Sealing	O-Ring (NBR)		
Diaphragm	Nylon Reinforced NBR Rubber		
Spring	Stainless Steel ASTM A276 Type 304 (1.4310)		

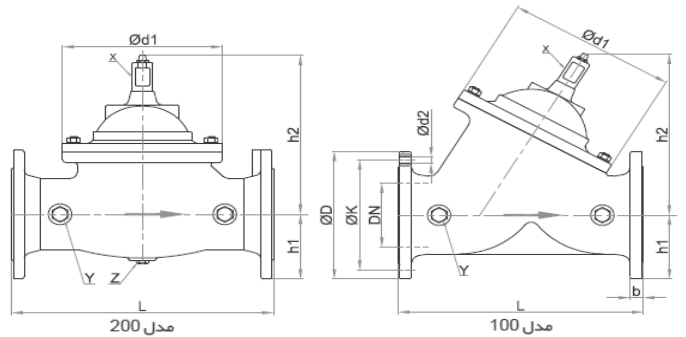

Dimension:



DN mm	PN bar	L mm	ØD mm	ØK mm	Ød2 mm	n	b mm	h1 mm	h2 mm	Ød1 mm	مدل	X in	Y in	Z in	Weight Kg
50	10,16	230	165	125	19	4	19	83	140	143	200	G 3/8"	G 3/8"	G 1/4"	17
65	10,16	290	185	145	19	4	19	93	185	200	200	G 3/8"	G 3/8"	G 3/8"	27
80	10,16	310	200	160	19	8	19	100	185	200	200	G 3/8"	G 1/2"	G 3/8"	31
100	10,16	350	220	180	19	8	19	110	230	245	100,200	G 1/2"	G 1/2"	G 3/8"	41
125	10,16	400	250	210	19	8	19	125	240	245	100	G 1/2"	G 1/2"	G 3/8"	50
150	10,16	480	285	240	23	8	19	143	324	335	100	G 1/2"	G 1/2"	G 3/8"	80
200	10	600	340	295	23	8	20	178	370	430	100,200	G 1/2"	G 3/8"	—	135
	16		340	295	23	12	20								
250	10	730	395	350	23		22	200	390	430	100,200	G 1/2"	G 3/8"	G 3/8"	165
	16		405	355	28	12	22								
300	10	850	445	400	23	12	24.5	208	488	560	100,200	G 1"	G 1/2"	G 1/2"	300
	16		460	410	28		24.5								
350	10	980	505	460	23	16	24.5	253	650	712	200	G 1 1/4"	G 1/2"	—	583
	16		520	470	28		26.5								
400	10	1100	565	515	28	16	24.5	283	650	712	200	G 1 1/4"	G 1/2"	—	620
	16		580	525	31		28								
450	10	1200	615	565	28	20	25.5	312.5	715	712	200	G 1 1/4"	G 1/2"	—	765
	16		640	585	31	20	30								
500	10	1250	670	620	28	20	26.5	345	781	900	200	G 1"	G 1/2"	—	950
	16		715	650	34		31.5								
600	10	1450	780	725	31	20	30	400	781	900	200	G 3/4"	G 1/2"	—	1300
	16		840	770	37		36								
700	10	1650	895	840	31	24	32.5	458	1068	1226	200	G 3/4"	G 1/2"	—	2550
	16		910	840	37		39.5								
800	10	1850	1015	950	34	24	35	593	1068	1226	200	G 3/4"	G 1/2"	—	2800
	16		1025	950	41		43								
1000	10	2250	1230	1160	37	28	40	620	1453	1530	200	G 3/4"	G 1"	—	4700
	16		1255	1170	44	28	50	632.5							