



®

NIRAB CO.

Manufacturer of Industrial Valves
and Relevant Equipment



Gearbox

Gearbox

Mirab Industrial Group (Privately held co.) started its activity in 1979 with the production of all kinds of industrial valves and related equipment. Relying on technical knowledge and extensive experience over several decades of production and in response to the needs of the industry, it was decided that the Quarter-turn Gearboxes which are applicable in its manufactured valves, offers separately in several sizes and designs to the target industries.

Functional Test:

All gearboxes are produced and tested in the Mirab co. Functional test is done by applying with minimum double of the torque which is required for input for the maximum output torque.

Degree of Protection:

All gearboxes are certified to IP65 & IP68 grade according to IEC 60529 standard.

Lifetime:

The Lifetime of gearbox in case of proper use and timely service and using the maximum output torque mentioned in the table, is at least 15,000 full cycles (open-close-open). The lifetime of gearbox can be increased, by less using of maximum torque output. If operation of gearbox with the maximum output torque exceeds, the lifetime will be drastically reduced. For example, if we operate the gearbox with 140% of the maximum output torque, the lifetime will be reduced to one-third, i.e. 5,000 full cycles.

Lubricant:





Grease, washers and O-rings must be thoroughly cleaned and replaced every 5 years or 5000 full cycles (open-close-open).

Warranty:

In case of correct operation, all gearboxes include 2-years warranty and 10 years of after-sales service.

Gearbox Specification

According to the below table and considering the appropriate reliability factor, you can choose your desired model and see more specifications and its dimensions in the following pages:

Group Name	Gearbox type	Max. Output Torque (N.m)	Top Flange EN ISO 5211 (mm)	Photo
MGAL	MGAL05	125	F5/F7	
	MGAL07	250	F7	
	MGDI10	500	F10	
MGS Type 1	MGS50	500	F10	
	MGS63	1000	F12	
	MGS80	2000	F12, F14	
	MGS100	4000	F16	
	MGS100 + MVZ 4.3	4000	F16	
MWG	MWG 130 + MZI 217	12,000	F16, F25	
	MWG 170 + MZI 563	21,000	F25, F30	
	MWG 210 + MZI 864	42,000	F30, F35	
	MWG 270 + MZI 1751	84,000	F35, F40	
MGS Type 2	MGS320 + MGZ 30	90,000	F40	
	MGS410 + MGZ 30	180,000	F48	
	MGS512 + MGZ 40	360,000	F60	

Quarter-Turn Gearbox MGAL

Model: MGAL05, MGAL07, MGDI10

Output Torque: 125 - 500 N.m

Gearbox Specification:

The swing angle of these gearboxes is up to 95 degrees, which can be adjusted independently with the outer screws of the gearbox housing after installation and lock with a nut. The gearbox housing in MGAL model is made of die-cast aluminum, and in the MGDI model is made of cast ductile iron. The main gear is also made of cast ductile iron. The drilling standard of gearbox housing is provided according to EN ISO 5211 and dimensional table.

Note: The rolled steel Handwheel is assembled on this model of gearboxes and only can be provided manually.

Coating system:

MGAL models with aluminum body are coated with black color epoxy powder paint with 50 microns thickness

The MGDI model with cast iron body is coated with Grey (RAL7001) electrostatic epoxy powder paint with 120 microns thickness.

For special requirements, it is possible to apply special coating as per order.

Application:

With degree of protection against dust and water, and IP65 certified according to IEC 60529 standard can be installed indoors and outdoors with ambient temperatures of -25°C to 70°C

These gearboxes can be used to be installed directly on all types of quarter turn valves such as Butterfly, Ball, and Plug. Mirab Co. apply this type of gearbox for wafer type valves up to size DN300.



Dimension of MGAL Gearbox:

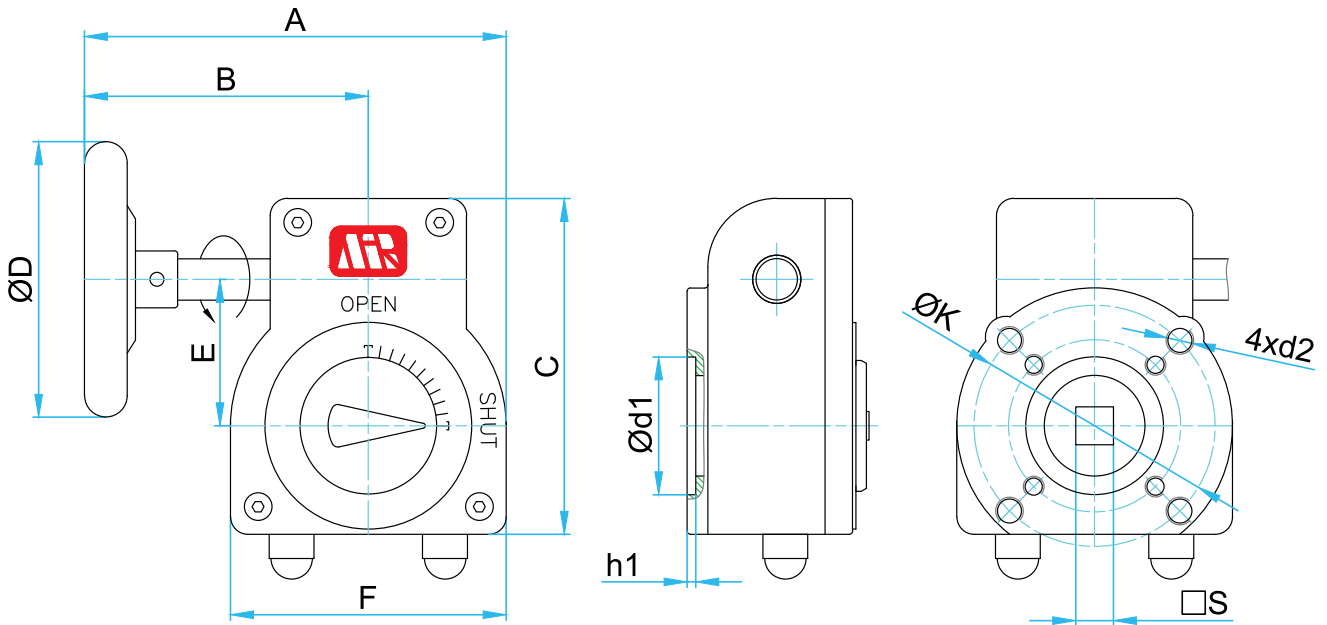

Type	Dimension											Valve attachment
	Φ K mm	Φ d2 mm	□ S +0.05 mm	Φ d1 mm	h1 mm	A mm	B mm	F mm	C mm	E mm	D mm	EN ISO 5211
MAL05	50	M6	10	--	--	150	110	80	110	42	120	F05
	70	M8	12	--	--							F07
MGAL07	70	M8	16	60	3	169	119	100	133	50	200	F07
MGDI10	102	M10	22	--	--	291	218	146	155	60	260	F10

Type	Output Torques Nm	Max. Input Torques Nm	Reduction ratio	Valve attachment EN ISO 5211	Turns for 90°	Limit Adjust	Weight Kg
MGAL05	125	13	40:1	F05/ F07	10	±5	1.45
MGAL07	250	21	37:1	F07	9.25	±5	2.1
MGDI10	500	39	45:1	F10	11.25	±5	5.2

Part List of MGAL Gearbox :

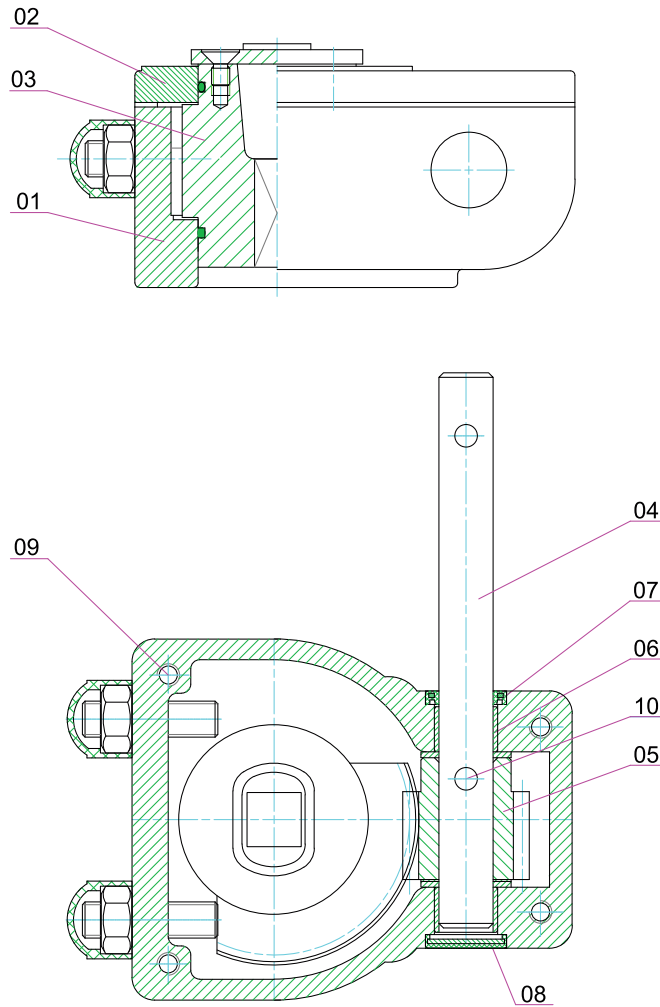

Part No.	Part Name	Part Material
1	Housing	* Aluminum
2	Housing Cover	* Aluminum
3	Worm Wheel	Ductile Iron
4	Shaft	Stainless Steel
5	Worm Shaft	Carbon Steel
6	Bushing	Brass
7	Seal Kit	NBR
8	Cap	NBR
9	Socket Screw	DIN ISO 898-1 Property Class 8.8, Zinc Plated
10	Pin	Carbon Steel

* Cast iron material for MGDI model.

Quarter-Turn Gearbox MGS Type 1

Model: MGS50, MGS63, MGS80, MGS100

Output Torque: 500 - 4000 N.M

Gearbox Specification

In these Gearboxes, torque is derived from worm shaft and worm wheel.

The swing angle of these gearboxes is up to 95 degree, the start and stop end can be changed by independently adjusting the chuck nuts of the worm shaft.

The gearbox housing is made of Ductile cast iron. Worm shaft is produced in one piece by turning machine from special grade of heat treatable steel. The main gear is also made of special grade of ductile cast iron.

Drilling standard for gearbox housing is done according to EN ISO 5211 and dimensional table.

Gearbox model MGS100 may be delivered with or without reduction gear MGZ4.3.

Note: These gearboxes are normally equipped with handwheel and can also be delivered with electrical actuator upon request, in which case some linkage part is needed.

Coating system:

The cast iron body and cover after cleaning and shot blasting is coated with Grey (RAL7001) electrostatic epoxy powder paint.



MGS Gearbox without Reduction Gear



MGS Gearbox with Reduction Gear

Application:

With degree of protection against dust and water, and IP65 & IP68 certified according to IEC 60529 standard can be installed indoors and outdoors with ambient temperatures of -25°C to 70°C .

These gearboxes can be used to be installed directly on all types of quarter turn valves such as Butterfly, Ball, and Plug.

Mirab Co. apply this type of gearbox for wafer and Lug type butterfly valves.

Type	output torques Nm	Suitable primary reduction gearing				Max. Input torques Nm	Valve attachment		Turns for 90°	Factor	Input Shaft Φ mm	Weight MGS+ MGZ Kg
		Type	MGS	MGZ	MGZ/ MGS		EN ISO 5211	Shaft max. Φ mm				
MGS50	500	--	55:1	--	55:1	30	F10	38	13.75	16.7	16	7
MGS63	1000	--	51:1	--	51:1	60	F12	50	12.75	16.7	20	12
MGS80	2000	--	53:1	--	53:1	110	F12, F14	60	13.25	18.2	20	14.4
MGS100	4000	--	52:1	--	52:1	214	F16	80	13	18.7	30/20	34.1
		MVZ4.3	52:1	4:1	208:1				52	70		

Part List of MGS Type 1 Gearbox:

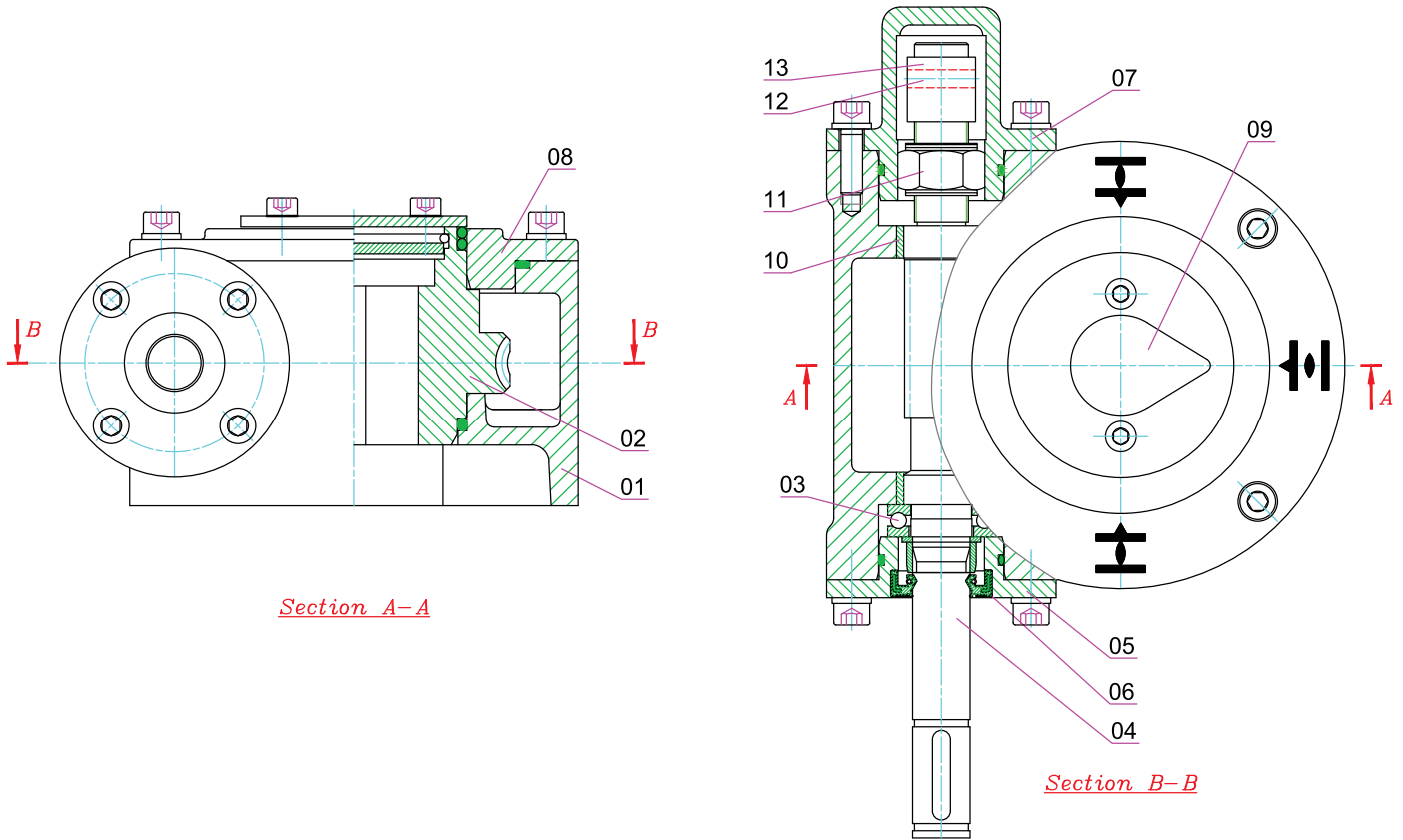

Part No.	Part Name	Part Material
1	Housing	Ductile Iron
2	Worm Wheel	Special Ductile Iron
3	Bearing	Carbon Steel
4	Worm Shaft	Carbon Steel
5	Bearing Cover	Cast Iron
6	Seal kit	EPDM (NBR on Request)
7	End Stop	Cast Iron
8	Housing Cover	Cast Iron
9	Pointer Cover	Carbon Steel
10	Bushing	Brass
11	Travelling Nut	Carbon Steel
12	Pin	Carbon Steel
13	End Stop Nut	Steel

Dimension of MGS Type 1 Gearbox:

• **MGS50**

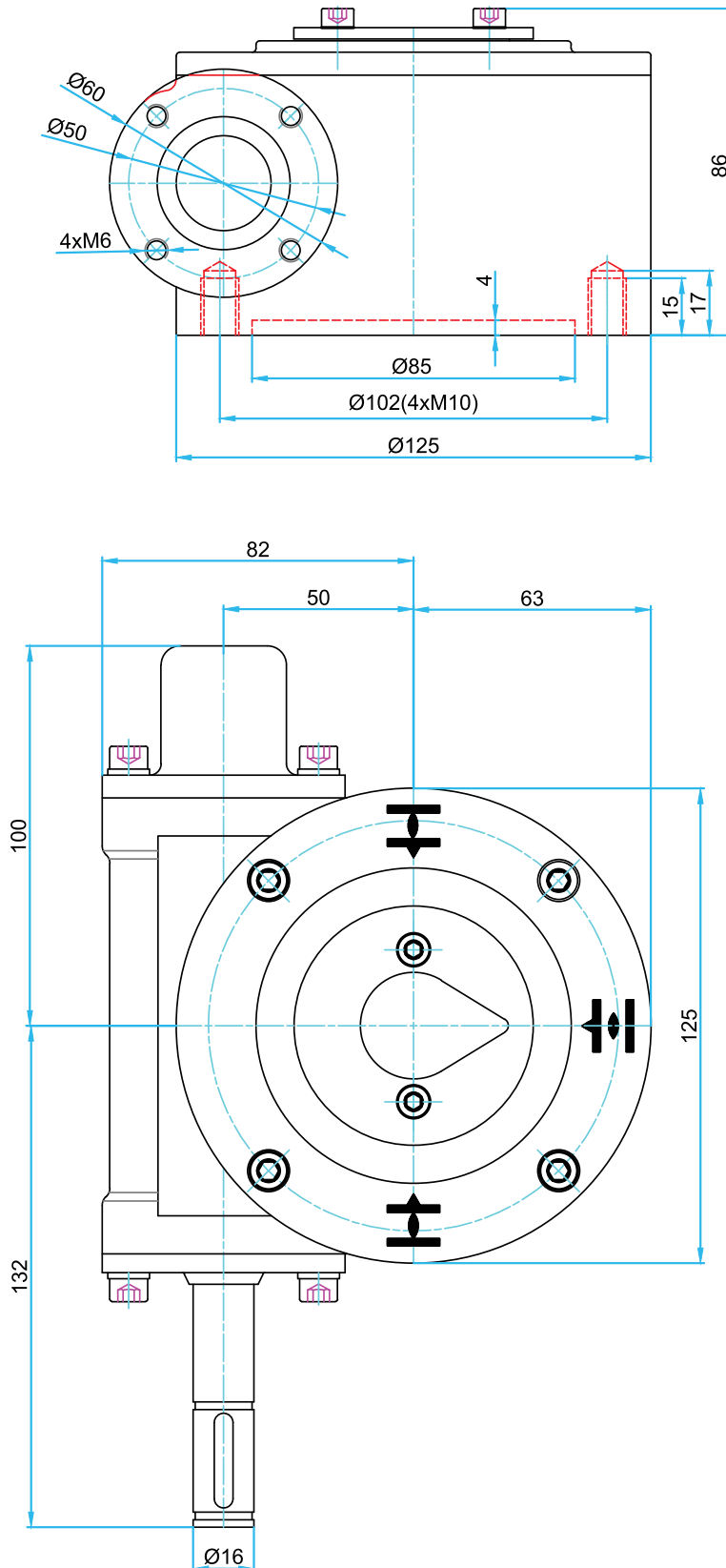

• **MGS63**

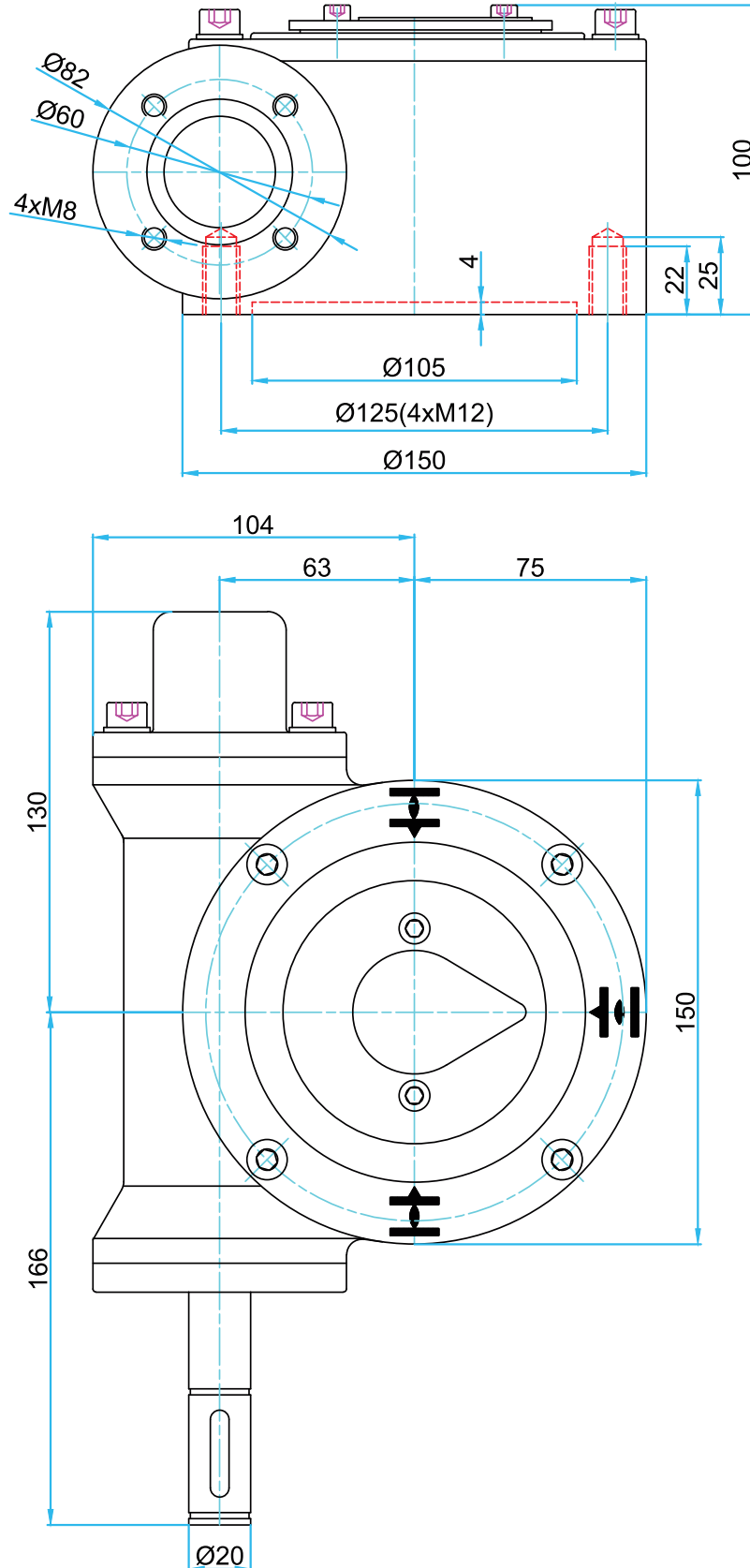

• **MGS80**

F14

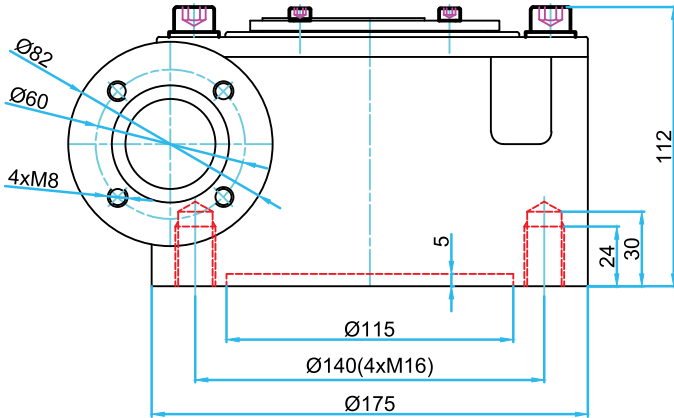

F12

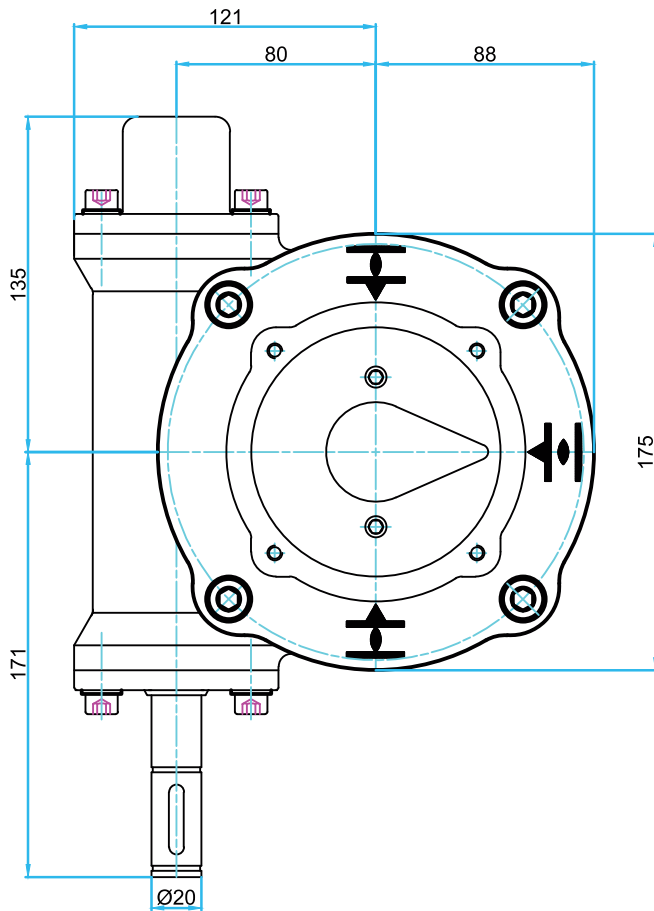
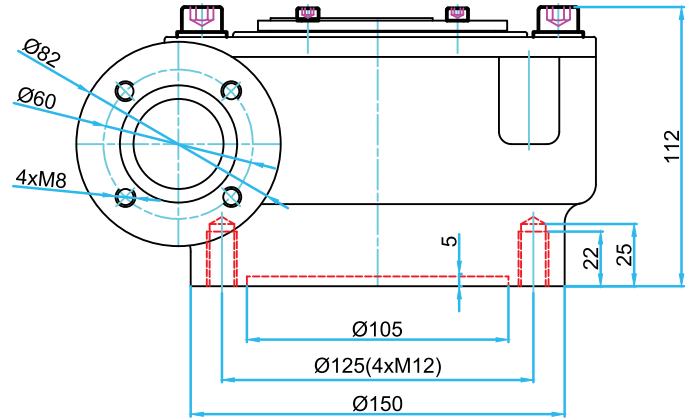

- MGS100
- MGS100+VZ4.3

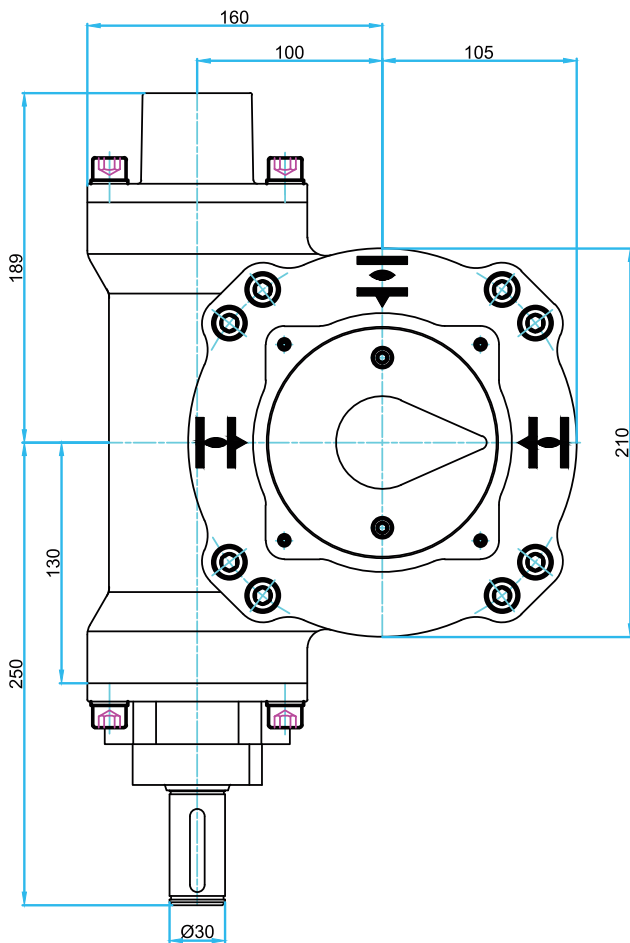
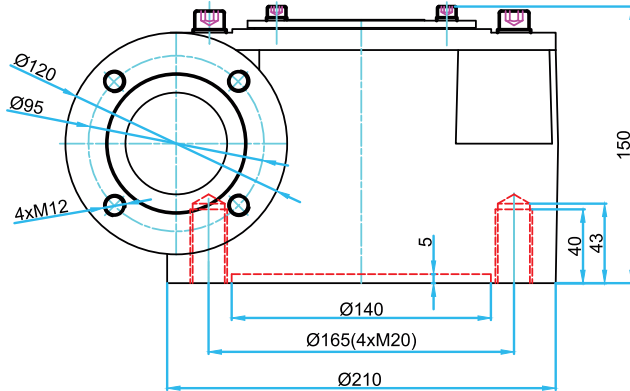

With MVZ4.3

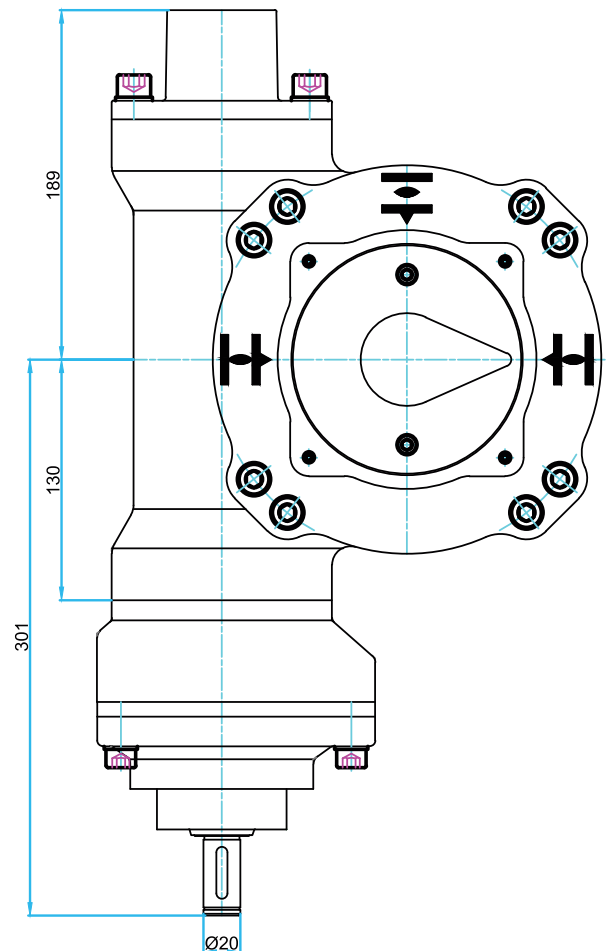

Quarter-Turn Gearbox MWG

Model: MWG130, MWG170, MWG210, MWG270

Output Torque: 12000 - 84000 N.m

Gearbox Specification:

In these gearboxes, torque is derived from internal and external gears in reduction gear and then by worm shaft and worm wheel of main gearbox. Therefore, despite its low weight, with it is possible to provide high torque with high reduction ratio. The worm shaft is fixed inside the shaft by a spline and receives the movement from reduction gear and transfers it to the worm wheel.

The swing angle of these gearboxes is up to 95 degrees, which can be adjusted independently with the outer screws of the gearbox housing after installation and lock with a nut.

The gearbox housing is made of Ductile cast iron. Worm shaft is produced in one piece by turning machine from special grade of heat treatable steel. The main gear is also made of special grade of ductile cast iron.

Drilling standard for gearbox housing is done according to EN ISO 5211 and dimensional table.

Note: These gearboxes are normally equipped with handwheel and can also be delivered with electrical actuator upon request, in which case some linkage part is needed.

Coating system:

The cast iron body and cover after cleaning and shot blasting is coated with Grey (RAL7001) electrostatic epoxy powder paint.



Application:

With degree of protection against dust and water, and IP65 & IP68 certified according to IEC 60529 standard can be installed indoors and outdoors with ambient temperatures of -25° C to 70° C .

These gearboxes can be used to be installed directly on all types of quarter-turn valves such as Butterfly, Ball, and Plug.

Mirab Co. apply this type of gearbox for wafer, Lug and flanged type butterfly valves.

Type	Max. output torque to Nm	Suitable primary reduction gearing				Max. input torques Nm	Valve attachment		Turns for 90°	Factor	Input Shaft Φ mm	Input mounting flange for multi turn actuator	Weight approx. Kg
		Type	MWG	MZI	MWG/MZI		EN ISO 5211	Shaft max. Φ mm					
MWG 130	12,000	MZI 217	52:1	4.17:1	217:1	172	F16/ F25	90	54.25	69.8	20	F10/ F14	48
MWG 170	21,000	MZI 563	54:1	10.4:1	563:1	120	F25/ F30	110	141	175	20	F10/ F14	75
MWG 210	42,000	MZI 864	53:1	16.3:1	864:1	164	F30/ F35	125	216	256	30	F10/ F14	129
MWG 270	84,000	MZI 1751	53:1	33:1	1751: 1	162	F35/ F40	160	438	518	30	F10/ F14	252

Part List of MWG Gearbox:

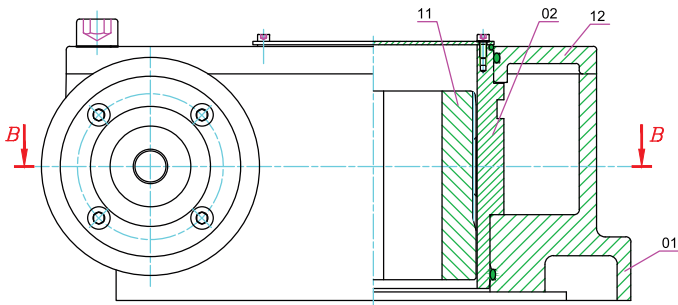

Section A-A

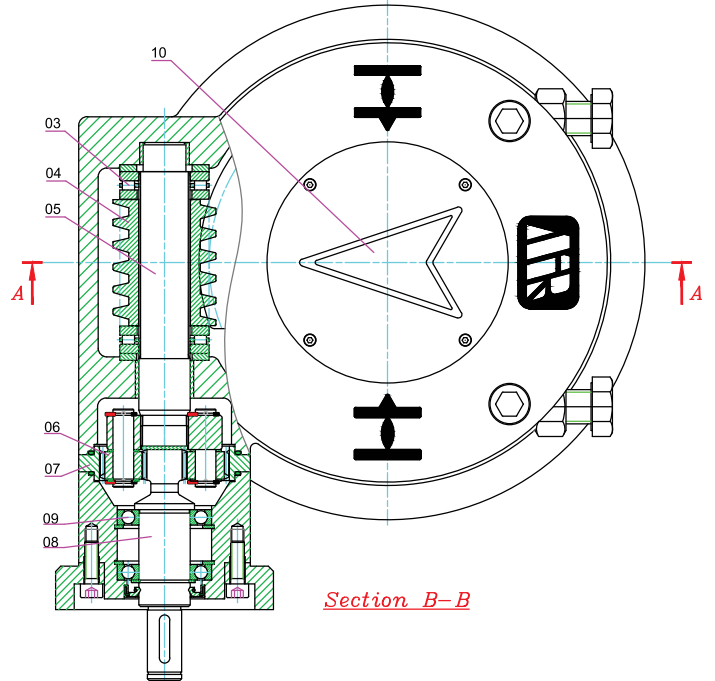

Section B-B

Part No.	Part Name	Part Material
1	Housing	Ductile Iron
2	Worm Wheel	Special Ductile Iron
3	Bearing	Carbon Steel
4	Worm Shaft	Carbon Steel
5	Shaft	Carbon Steel
6	Planet Carrier	Carbon Steel
7	Internal Geared Wheel	Ductile Iron
8	Shaft	Carbon Steel
9	Bearing	Carbon Steel
10	Pointer Cover	Carbon Steel
11	Coupling	Carbon Steel
12	Housing Cover	Ductile Iron

Dimension of MWG Gearbox :

- MWG130 + MZI 217

F16

F25

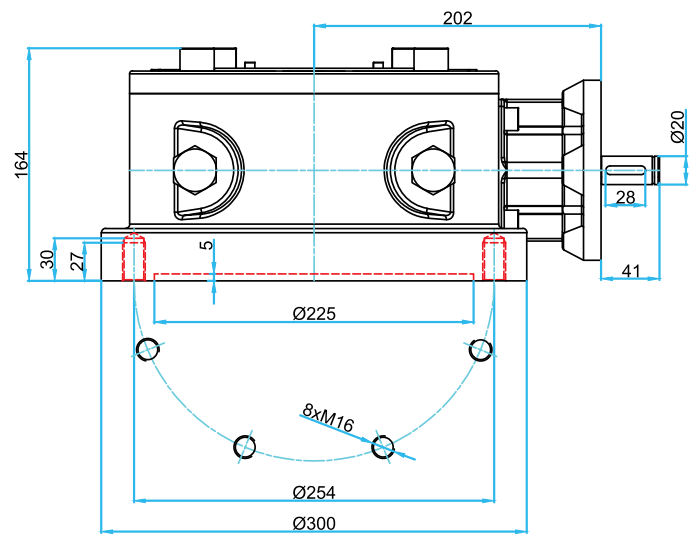
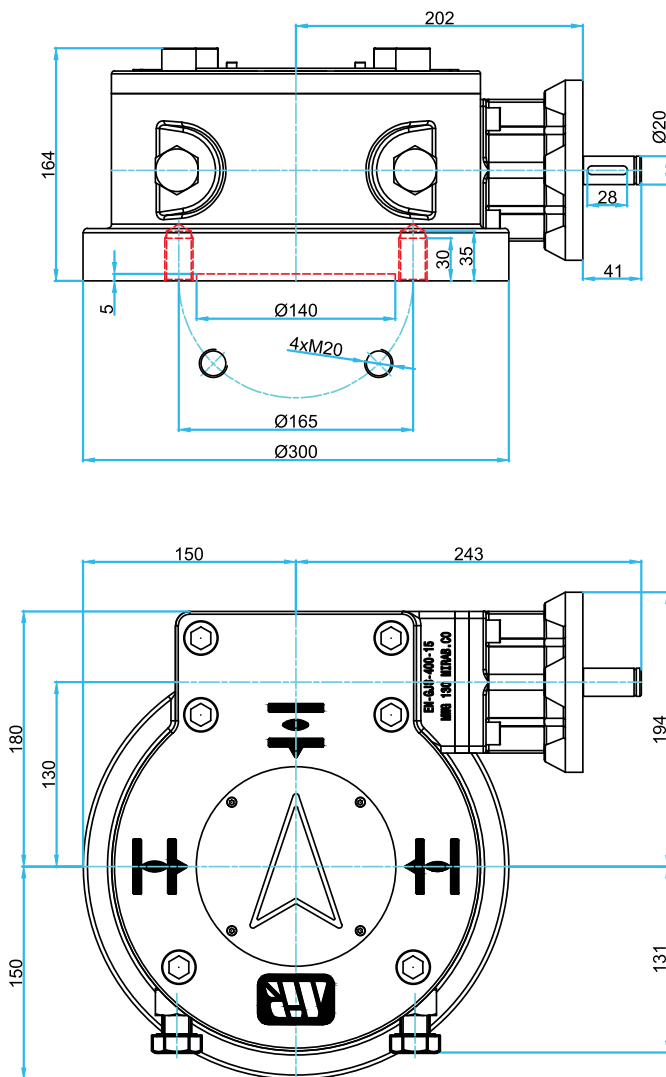

• MWG 210 + MZI 864

F30

F35

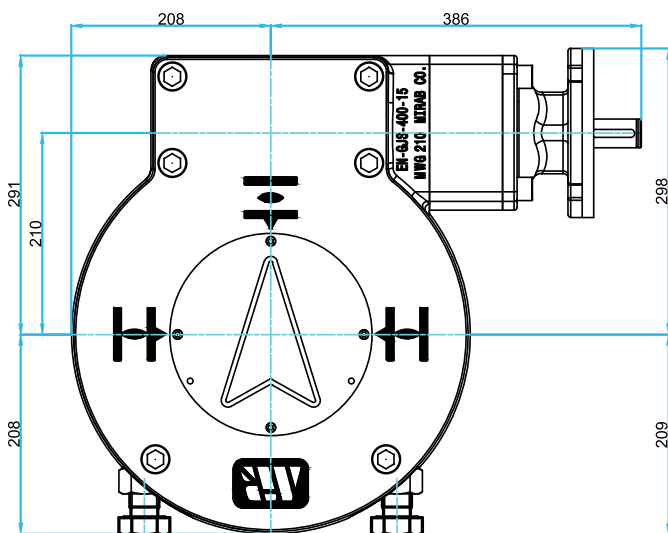
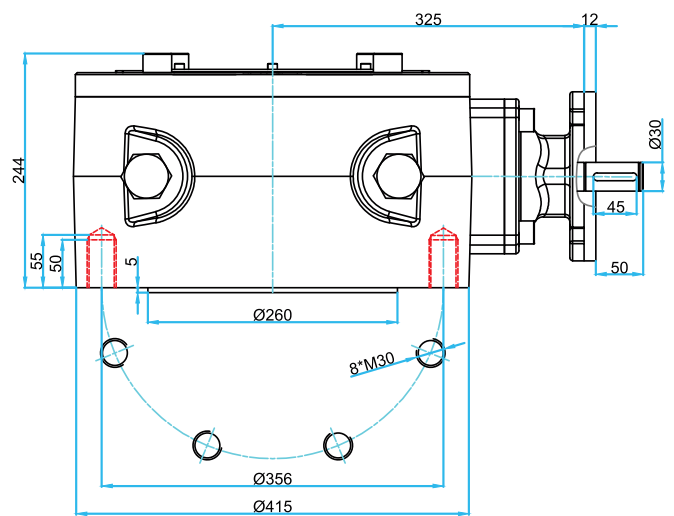
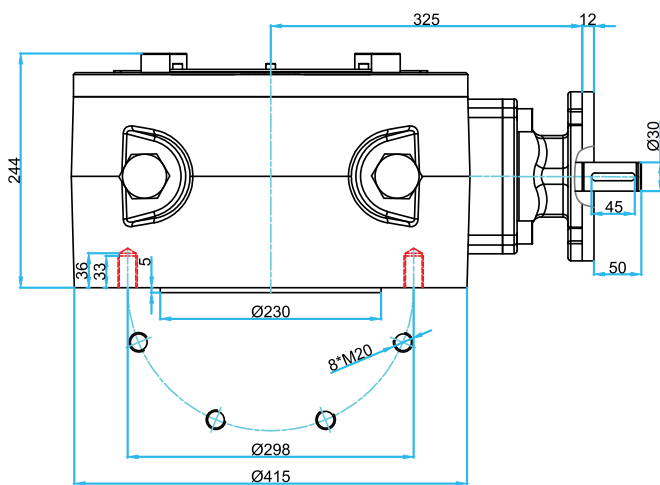

Quarter-Turn Gearbox MGS Type 2

Model: MGS320, MGS410, MGS512

Output Torque: 190000 - 360000 N.m

Gearbox Specification:

In these gearboxes, torque is derived from internal and external gears in reduction gear and then by worm shaft and worm wheel of main gearbox. Therefore, despite its low weight, with it is possible to provide high torque with high reduction ratio. The swing angle of these gearboxes is up to 95 degree, the start and stop end can be changed by independently adjusting the chuck nuts of the worm shaft.

The gearbox housing is made of Ductile cast iron. Worm shaft is produced in one piece by turning machine from special grade of heat treatable steel. The main gear is also made of special grade of ductile cast iron.

Drilling standard for gearbox housing is done according to EN ISO 5211 and dimensional table.

Any size of these Gearboxes may be delivered with or without reduction gear 8:1, 16:1 or 32:1.

Note: These gearboxes are normally equipped with handwheel and can also be delivered with electrical actuator upon request, in which case some linkage part is needed.

Coating system:

The cast iron body and cover after cleaning and shot blasting is coated with Grey (RAL7001) electrostatic epoxy powder paint.



Application:

With degree of protection against dust and water, and IP65 & IP68 certified according to IEC 60529 standard can be installed indoors and outdoors with ambient temperatures of -25° C to 70° C .

These gearboxes can be used to be installed directly on all types of quarter-turn valves such as Butterfly, Ball, and Plug.

Mirab Co. apply this type of gearbox for wafer, Lug and flanged type butterfly valves.

Type	output torques		Suitable primary reduction gearing				Input torques		Valve attachment		Turns for 90°	Factor	Input Shaft	Weight	
	100% max. Nm	140% max. Nm	Type	MGS	MGZ	MGS/MGZ	at output torque of		EN ISO 5211	Shaft max. Φ mm					
MGS320	63,000	90,000	--	54:1	--	--	2636	3766	F40	200	13.5	24	60	520	
			MGZ30	54:1	8:1	432:1	389	556			108	165	30/40		630
				54:1	16:1	864:1	194	277			216	330	30/40		
				54:1	32:1	1728:1	97	138			432	660	30		
MGS410	125,000	180,000	--	54:1	--	--	5144	7407	F48	250	13.5	24	80	980	
			MGZ30	54:1	8:1	432:1	758	1091			108	165	40		1100
				54:1	16:1	864:1	379	544			216	330	30		
				54:1	32:1	1728:1	189	272			432	660			
MGS512	250,000	360,000	--	54:1	--	--	10684	15385	F60	315	13.5	24	100	1800	
			MGZ40	54:1	16:1	864:1	786	1132			216	330	40		2000
				54:1	32:1	1728:1	393	566			432	660	30		

Part List of MGS Type 2 Gearbox :

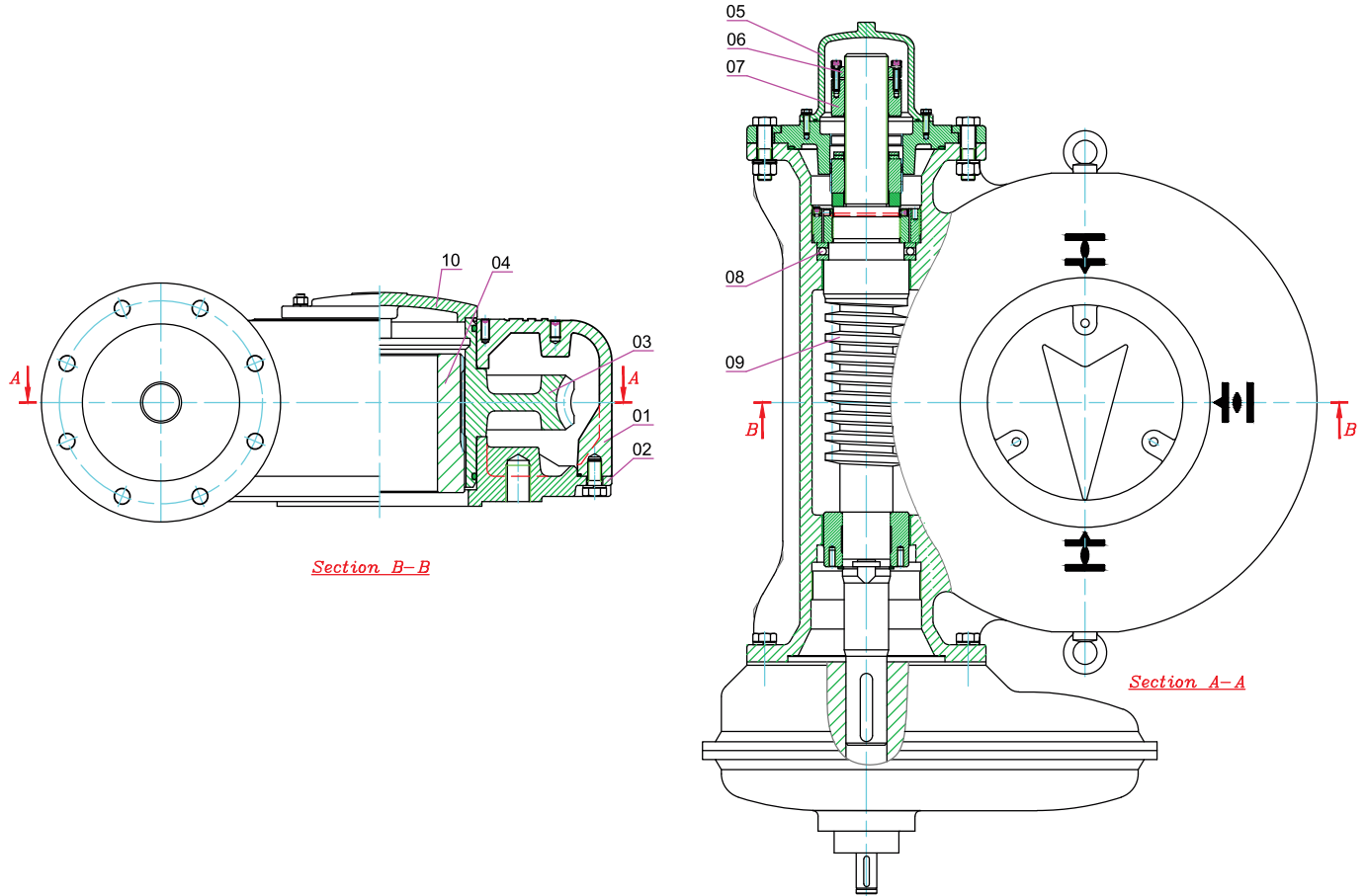

Part No.	Part Name	Part Material
1	Housing	Ductile Iron
2	Mounting Flange	Ductile Iron
3	Worm Wheel	Special Ductile Iron
4	Coupling	Carbon Steel
5	Protective Cap	Cast Iron
6	End Stop Nut Retainer	Carbon Steel
7	End Stop Nut	Carbon Steel
8	Bearing	Carbon Steel
9	Worm Shaft	Carbon Steel
10	Pointer Cover	Cast Iron

Dimension of MGS Type 2 Gearbox:

- MGS320+MGZ30

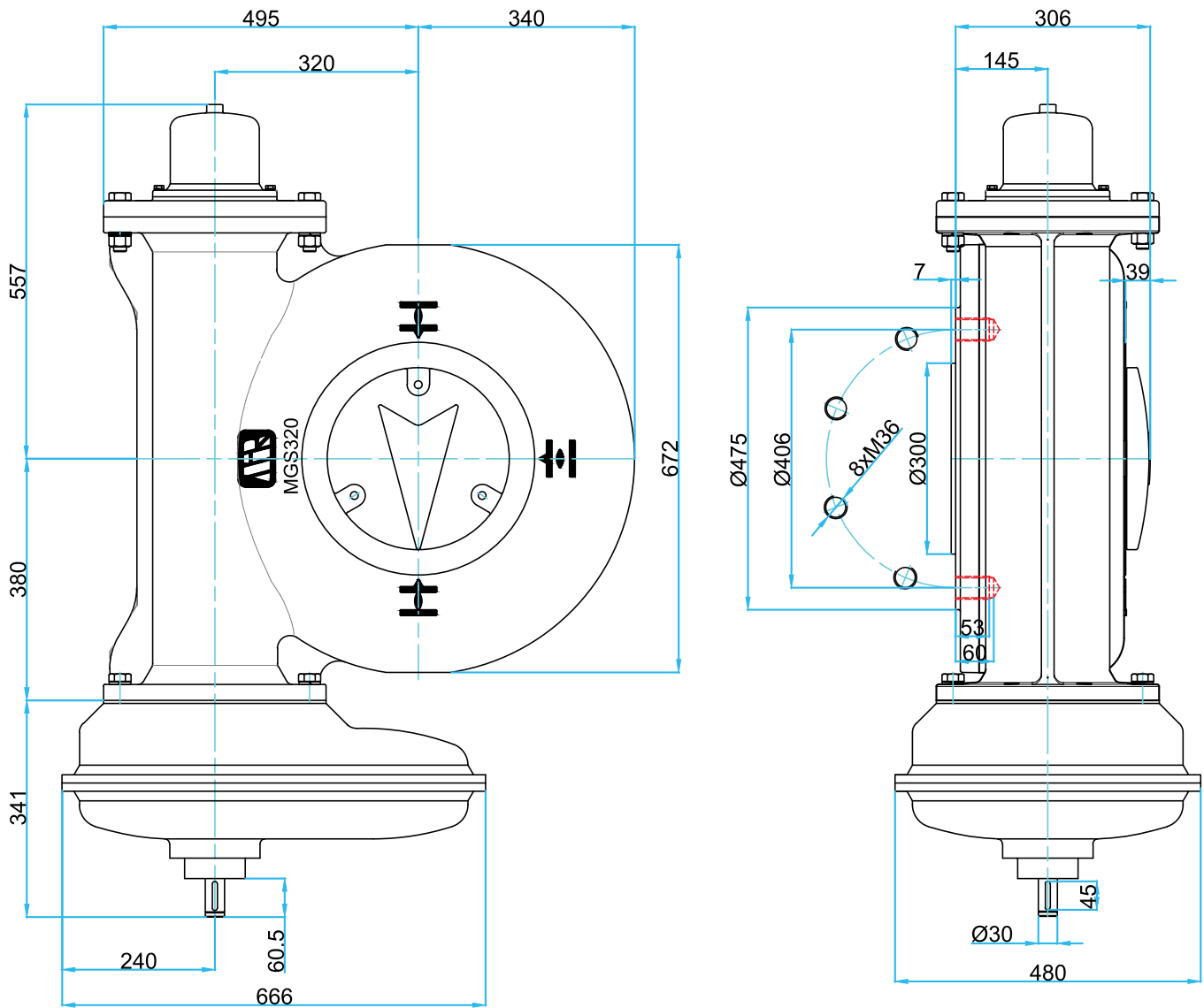

• **MGS410+MGZ30**

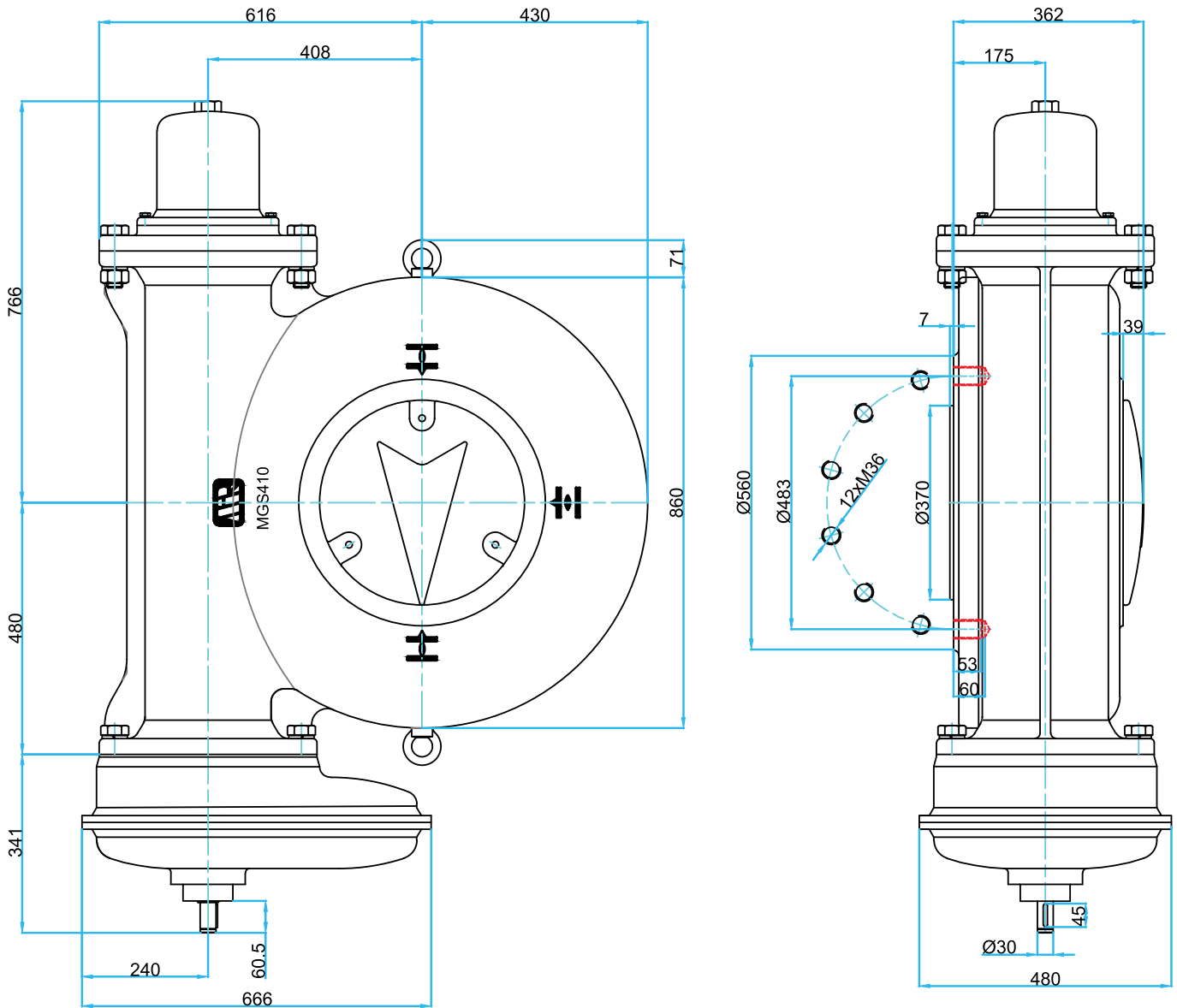

• MGS512+MGZ40

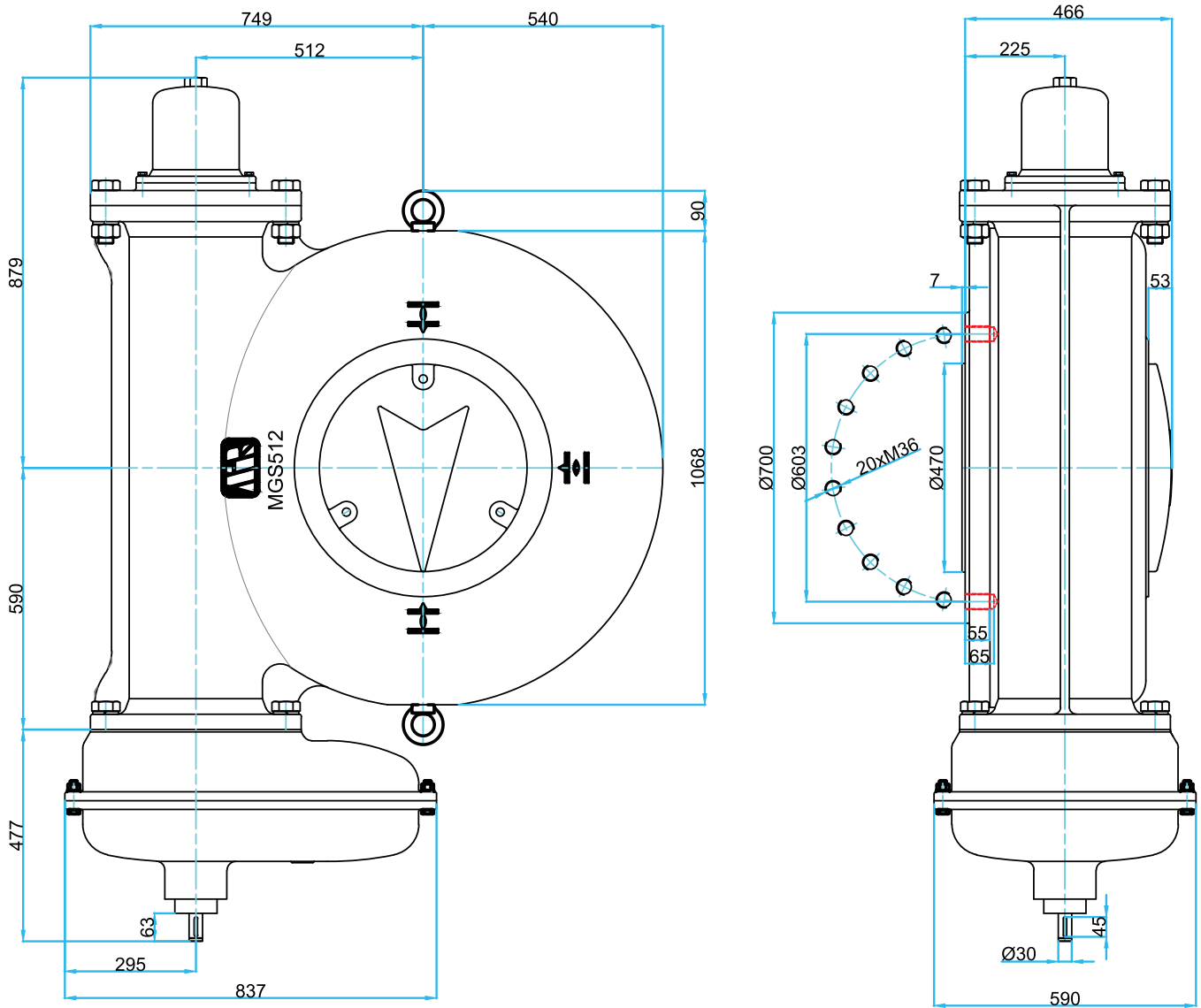

IP65 Certificate for Mirab Gearbox:



شرکت آزمایشگاه‌های صنایع انرژی
 دارنده گواهینامه ISO IEC 17025 / 17065
 ISO IEC 17025 / 17065 Accredited

Document Code: LQF-708-02-01 page 1 of 12
 Document Review Date: 01.07.30 Test Report Number : TL13-70461/1-T1

IP TEST REPORT

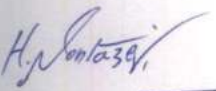
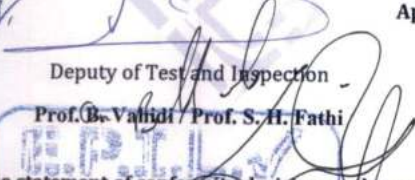

Project No.:	TL13-70461		
Equipment Under Test:	Worm Gearbox Enclosure		
Model/Type:	MGS 50	Rated Value:	---
IP:	IP65		
Manufacturer:	Mirab Co.		
Address:	No.75, Dadman Blvd., Shahrak-e Gharb, Tehran-Iran.		
Applicant:	Mirab Co.		
Address:	No.75, Dadman Blvd., Shahrak-e Gharb, Tehran-Iran.		
Tested According to:	IEC 60529 : 2019		
Testing Laboratory:	Energy & Power Industries Laboratories Co.		
Date of Sample Reception:	28-May-2024		
Date of tests:	11-Jun-2024		
Date of Issue:	24-Jun-2024		
Total number of pages:	12		
Test Result:	PASSED		

Tested by: Technical Expert
H. Montazeri

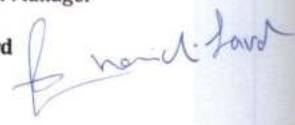
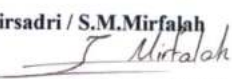
 Deputy of Test and Inspection
Prof. B. Valadi / Prof. S. H. Fathi

Verified by: Technical Manager
B. Hamidifard

 CEO/Deputy technical manager
S. M. Mirsadri / S.M. Mirfalah

The statement of conformity decision on the measured values is made based on guard band w=U, r=1 rule (ISO/IEC Guide 98-4). The specific false accept/reject risk is up to 2.5%.

ISO IEC 17025
 Accredited Lab

This report should not be reproduced in extracts without written approval by EPIL. Test result pertain to tested sample only. This report is not valid without Lab stamp.

سرگروه تکثیر این گزارش به صورت جزئی یا کلی بدون تایید کتبی اپیل ممنوع می باشد. نتایج آزمون‌ها تنها در رابطه با نمونه آزمون شده معتبر است. این گزارش بدون مهر فاقد اعتبار است.

دفتر مرکزی: تهران، خیابان ولیعصر، خیابان بزرگمهر، نبش فریمان، بن بست بوجاری صفت، پلاک ۴، طبقه ۳، واحد ۱۴.

کد پستی: ۱۴۱۶۸۵۴۵۲۳ | تلفن: ۰۲۱-۶۱۹۷۱۰۰۰ (+۹۸۲۱) | فکس: ۰۲۱-۶۶۱۷۴۲۸۳ (+۹۸۲۱)

آزمایشگاه: کیلومتر ۸ اتوبان کرج - قزوین، بلوار سوپا، شهرک تحقیقاتی کاوش، شرکت آزمایشگاه‌های صنایع انرژی.

کد پستی: ۳۳۶۵۱۶۶۵۵ | تلفن: ۰۲۱-۳۳۹۹۶۷۰۰ (+۹۸۲۶) | فکس: ۰۲۱-۳۳۹۹۶۷۱۵ (+۹۸۲۶)

www.epil.ir info@epil.com @epil_co epil-ir 09109104342 . 09109105352 . 09109104636

IP68 Certificate for Mirab Gearbox:



شرکت آزمایشگاه‌های صنایع انرژی
 دارنده گواهینامه ISO IEC 17025 / 17065
 ISO IEC 17025 / 17065 Accredited

Document Code: LQF-708-02-01
 Document Review Date: 01.07.30

page 1 of 12
 Test Report Number : TL13-70461-T1

IP TEST REPORT



Project No.:	TL13-70461		
Equipment Under Test:	Worm Gearbox Enclosure		
Model/Type:	MGS 50	Rated Value:	---
IP:	IP68 (2 m / 30 min)		
Manufacturer:	Mirab Co.		
Address:	No.75, Dadman Blvd., Shahrak-e Gharb, Tehran-Iran.		
Applicant:	Mirab Co.		
Address:	No.75, Dadman Blvd., Shahrak-e Gharb, Tehran-Iran.		
Tested According to:	IEC 60529 : 2019		
Testing Laboratory:	Energy & Power Industries Laboratories Co.		
Date of Sample Reception:	28-May-2024		
Date of tests:	11-Jun-2024		
Date of Issue:	24-Jun-2024		
Total number of pages:	12		
Test Result:	PASSED		



<p>Tested by: Technical Expert</p> <p style="text-align: center;">H. Montazeri</p> <p><i>(Signature)</i></p> <p style="text-align: center;">Deputy of Test and Inspection</p> <p style="text-align: center;">Prof. B. Vahidi / Prof. S. H. Fathi</p>	<p>Verified by: Technical Manager</p> <p style="text-align: center;">B. Hamidifard</p> <p><i>(Signature)</i></p> <p style="text-align: center;">CEO/Deputy technical manager</p> <p style="text-align: center;">S. M. Mirsadri / S.M. Mirfalah</p> <p><i>(Signature)</i></p>
---	---

Approved by:

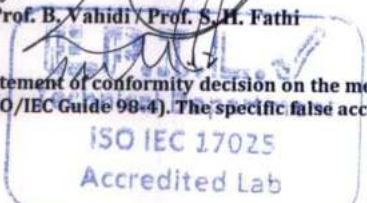

ISO IEC 17025
Accredited Lab

The statement of conformity decision on the measured values is made based on guard band w=U, r=1 rule (ISO/IEC Guide 98-4). The specific false accept/reject risk is up to 2.5%.

This report should not be reproduced in extracts without written approval by EPIL. Test result pertain to tested sample only. This report is not valid without Lab stamp.

Head-office: Unit 12, No. 2, Boujari Sefat Dead-End, Corner of Fariman St., Bozorgmehr St., Vali-Asr Ave., Tehran-Iran.
 Postal Code: 1416854523 Tel: (+9821) 61971 Fax: (+9821) 66174283
Lab: Kavosh Research City, Supa Blvd., 8th km of Karaj-Qazvin Freeway, Iran.
 Postal Code: 3365166551 Tel: (+9826) 34996700-14 Fax: (+9826) 34996715

هرگونه تکثیر این گزارش به صورت جزئی یا کلی بدون تایید کتبی اپیل ممنوع می باشد. نتایج آزمون‌ها تنها در رابطه با نمونه آزمون شده معتبر است. این گزارش بدون مهر فاقد اعتبار است.
 دفتر مرکزی: تهران، خیابان ولیعصر، خیابان بزرگمهر، نبش فریمان، بن بست بوخاری صفت، پلاک ۲، طبقه ۳، واحد ۱۲.
 کد پستی: ۱۴۱۶۸۵۴۵۲۳، تلفن: ۶۱۹۷۱-۰۶ (+۹۸۲۱) - فکس: ۶۶۱۷۴۲۸۳-۰۶ (+۹۸۲۱)
 آزمایشگاه: کیلومتر ۸ اتوبان کرچ - قزوین، بلوار سویا، شهرک تحقیقاتی کاوش، شرکت آزمایشگاه‌های صنایع انرژی.
 کد پستی: ۳۳۶۵۱۶۶۵۵۱، تلفن: ۳۴۹۹۶۷۰۰-۱۴ (+۹۸۲۶) - فکس: ۳۴۹۹۶۷۱۵ (+۹۸۲۶)

www.epil.ir info@epil.com @epil_co epil-ir 09109104342 , 09109105352 , 09109104636



IRAN

Head Office:

No. 6, West 1st Golbarg alley., Fakhar Moghaddam St., Dadman Blvd., Shahrak-e Gharb, Tehran, Iran

Tel: +98 (0)21 52609

Factory:

Shams Abad Industrial Complex, at the end of Sarvestan Blvd, Mirab Company

Tel: +98 (0)21 44005680

